

CBSE Question Paper 2018
Class 12 Engineering Graphics

Time allowed : 3 hours

Maximum Marks : 70

General Instructions :

1. Attempt all the questions.
 2. Use both sides of the drawing sheet, if necessary.
 3. All dimensions are in millimetres.
 4. Missing and mismatching dimensions, if any, may be suitably assumed.
 5. Follow the SP 46 : 2003 revised codes (with first angle method of projection).
 6. In question 2, no views of hidden edges or lines are required.
 7. In question 4, hidden edges or lines are to be shown in views without section.
 8. Give your answers according to questions.
-

1. **Answer the following Multiple Choice Questions. Print the correct choice on your drawing sheet. ($1 \times 5 = 5$)**

i. **The truncated lower portion of a pyramid is called**

- a. Prism
- b. Frustum
- c. Cube
- d. Cone

Ans. (b) Frustum.

ii. **In a single riveted lap joint, the plates to be joined are**

- a. In contact with each other at the ends
- b. Overlapping each other
- c. Inclined to each other
- d. Kept at a distance of 10 mm from each other

Ans. (b) Overlapping each other.

iii. **Which special type of Sunk key looks like a segment of a circular disc ?**

- a. Woodruff key



- b. Feather key
- c. Gib head key
- d. Rectangular taper key

Ans. (a) Woodruff key

iv. **Which of the following is not a part of an unprotected flange coupling ?**

- a. Gasket
- b. Shaft
- c. Sunk key
- d. Flange

Ans. (a) Gasket

v. **What is the purpose of crowning on the rim of a solid cast iron pulley ?**

- a. To make the belt slip off the rim
- b. To join the shaft with the rim
- c. To lubricate the rim
- d. To keep the belt in the middle of the rim

Ans. (d) To keep the belt in the middle of the rim.

2. i. **Construct an isometric scale. (4)**

ii. **A vertical triangular pyramid (base edge 40 mm and axial height 60 mm) is resting on its base on H.P. One of its base edges is perpendicular to V.P. Draw its isometric projection. Show the axis and indicate the direction of viewing. Give all dimensions. (7)**

iii. **A sphere (diameter 50 mm) is placed centrally on the top hexagonal face of a hexagonal prism (base edge 30 mm and height 40 mm). Two base edges of the prism are parallel to V.P. The common axis is perpendicular to H.P. Draw the isometric projection of the combination of solids. Show the common axis and indicate the direction of viewing. Give all dimensions. (13)**

Ans.

i. **Isometric Scale**



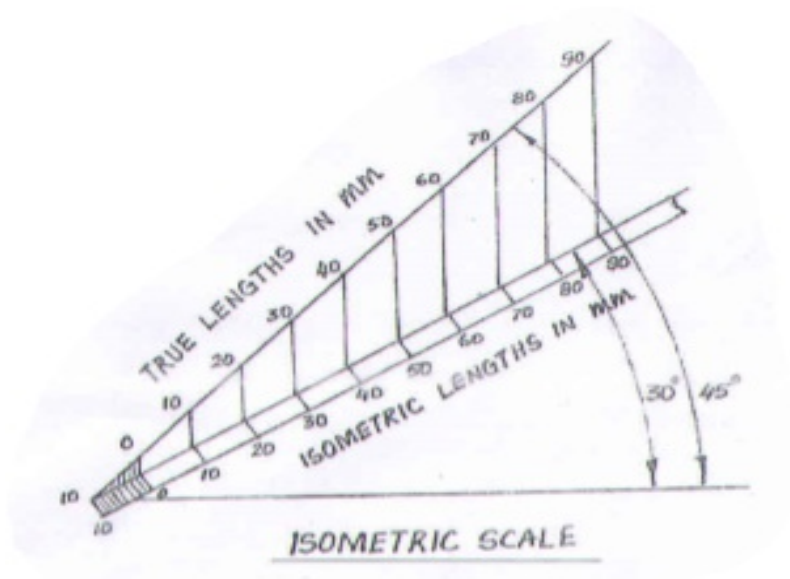

- Marking of divisions of 10 mm, including division of first part of 1 mm on true length.
- Projections from scale 1:1 to get points on isometric scale, construction of isometric scale.
- Printing 'True Length/Scale 1:1; 'Isometric Length/Isometric Scale' and marking angles of 30° & 45° .

ii. **Isometric Projection of a Triangular Pyramid**

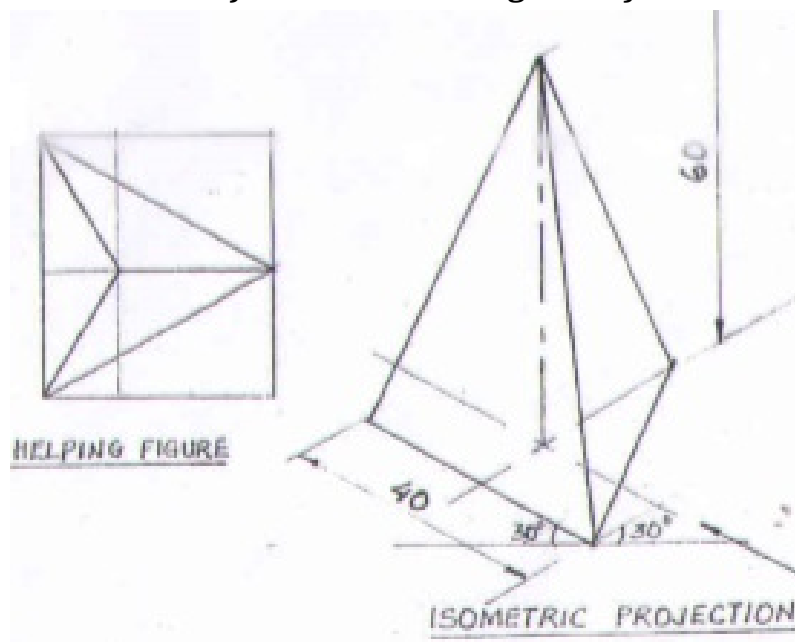

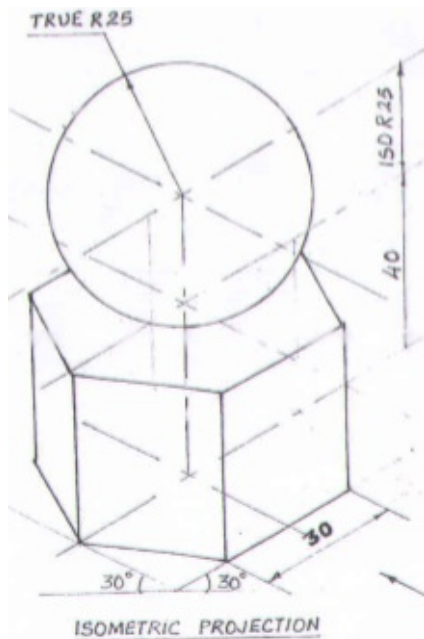

- Drawing helping figure of triangle.
- Drawing isometric triangle keeping one base edge perpendicular to V.P. either at left or at right.
- Drawing slant edges.
- Marking the axis and direction of viewing
- Dimensions.

iii. Hexagonal Prism

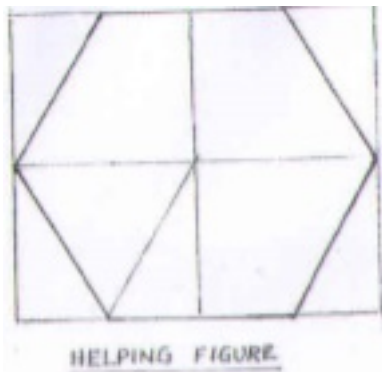

- Drawing helping figure.
- Drawing both isometric hexagons.
- Drawing vertical edges
- Dimensions.

Sphere

- Locating the centre of sphere with isometric radius.
- Drawing the circle of sphere with true radius.
- Marking the common axis, direction of viewing



iv. Dimensions.

3. i. Draw to scale 1 : 1, the standard profile of a B.S.W. Thread, taking enlarged pitch as 50 mm. Give standard dimensions. (8)

OR

Draw to scale 1 : 1, the front view and side view of a Square Headed Bolt of diameter 25 mm, keeping the axis vertical. Give standard dimensions.

- ii. Sketch freehand the front view and top view of a Grub Screw of size M20, keeping the axis vertical. Give standard dimensions. (5)

OR

Sketch freehand the front view and top view of a Flat Head Rivet of diameter 25 mm, keeping the axis vertical. Give standard dimensions.

Ans.

- i. B.S.W Thread Profile

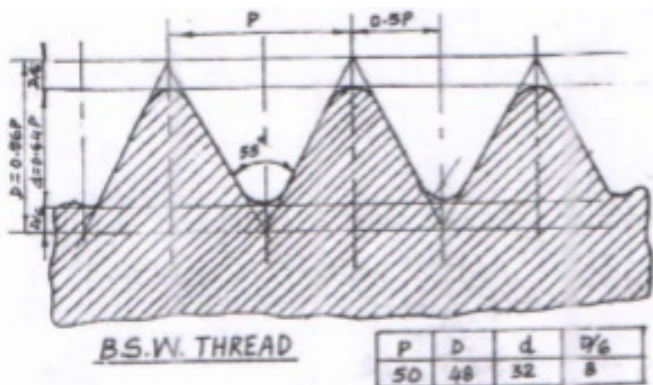

- Horizontal distance (equal to half of pitch), vertical distances ($D = 0.96P$, $D/6$) marked correctly.
- Drawing crests, roots of threads (minimum two) and flanks, drawn correctly.
- Drawing hatching lines and conventional break.
- Standard dimensions.

OR

Square Headed Bolt (with axis vertical)

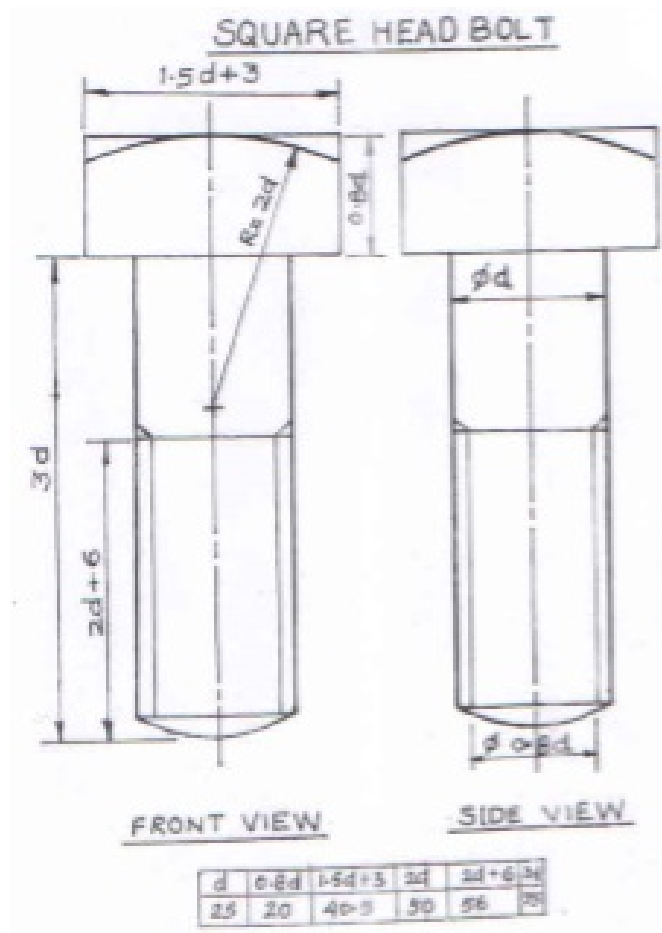

- a. Front View (A/F or A/C)
 - (i) Drawing shank of the bolt with threaded length.
 - (ii) Drawing head of the bolt with chamfering arc.
- b. Side View:
 - (a) Drawing shank of the bolt with threaded length.
 - (b) Drawing head of the bolt with chamfering arc.
- c. Standard dimensions.

As the front view and side view are identical, under the given condition, the dilemma of examinee is considered. If the examinee has attempted front view only with vertical axis or horizontal axis, then the marks allotted to side view will be added to front view.

ii. Grub Screw



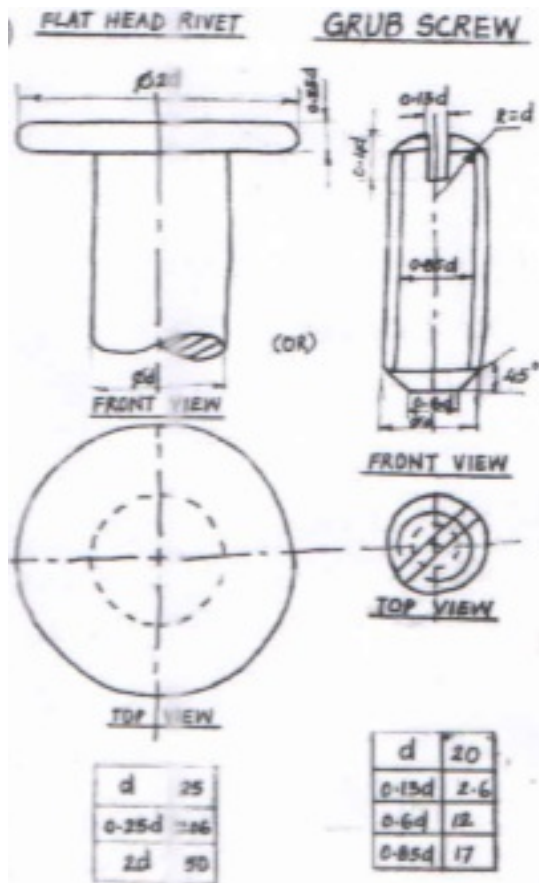

- a. Front view with its axis vertical.
- b. Top view.
- c. Standard dimensions.

OR

Flat Head Rivet

- a. Front view with its axis vertical.
- b. Top view.
- c. Standard dimensions.

4. **Figure-1 shows the details of parts of a Socket and Spigot Cotter Joint. Assemble these parts correctly and then draw the following views using scale 1 : 1.**
 - i. **Front view, upper half in section. (14)**
 - ii. **Side view, looking from the left. (8)**

Print the title and scale used. Draw the projection symbol. Give 6 important dimensions. (6)

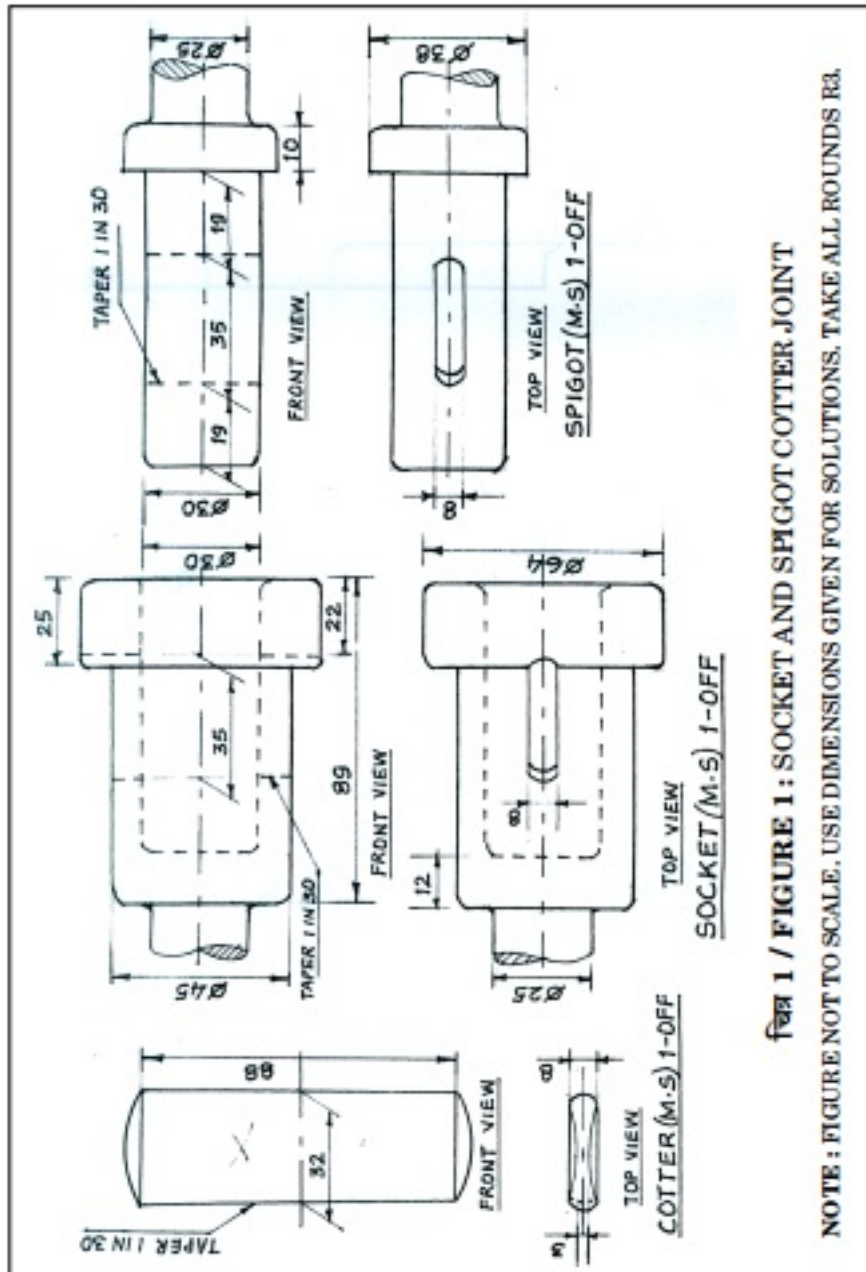

FIG 1 / FIGURE 1: SOCKET AND SPIGOT COTTER JOINT

NOTE: FIGURE NOT TO SCALE. USE DIMENSIONS GIVEN FOR SOLUTIONS. TAKE ALL ROUNDS R3.

OR

Figure-2, shows the assembly of a Bushed Bearing. Disassemble the parts correctly and then draw to scale 1 : 1 the following views of the following components. Keep the same position of both, Body and Bush, with respect to H.P. and V.P.

- i. Body :
 - a. Front view, left half in section. (8)
 - b. Top view. (7)
- ii. Bush :

- a. Full sectional front view. (4)
- b. Top view. (3)

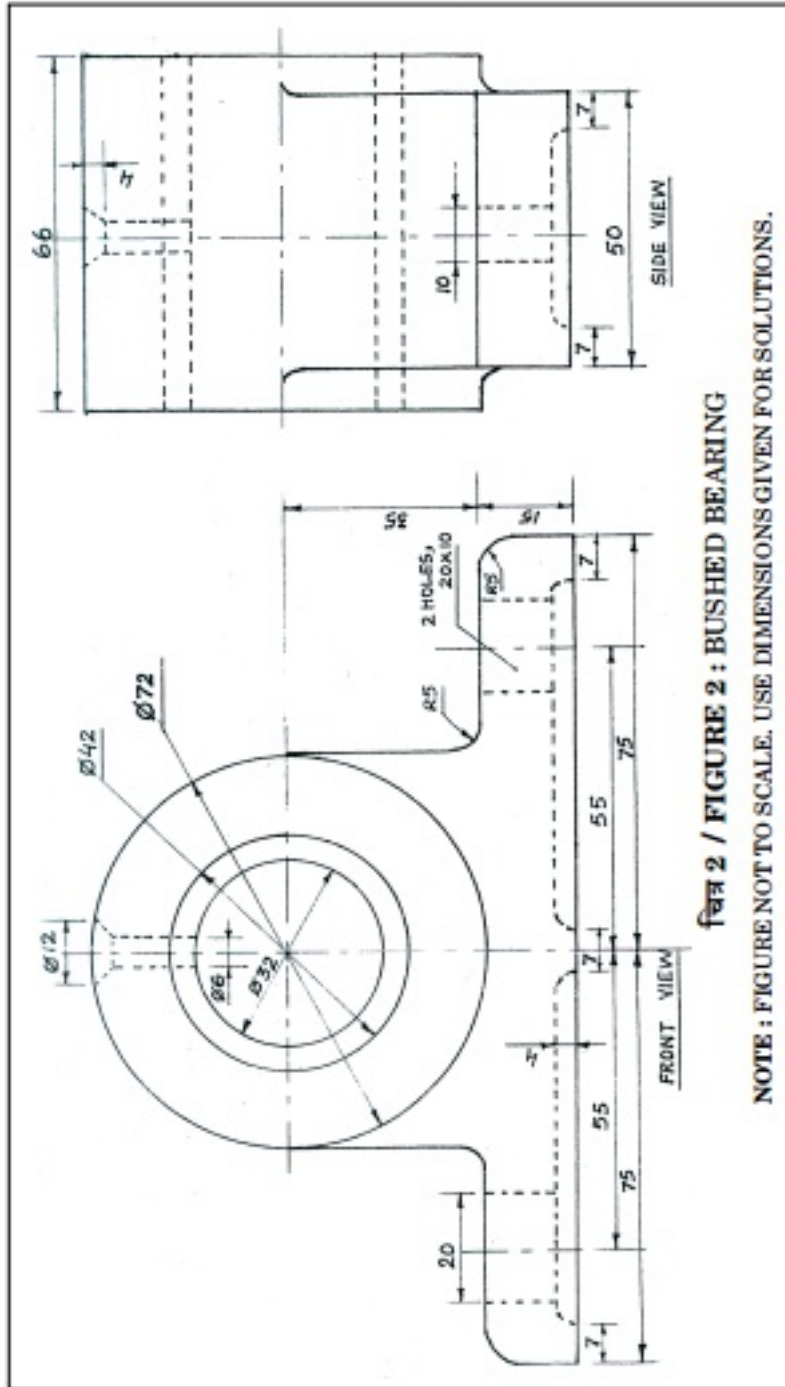

Print the titles of both and scale used. Draw the projection symbol. Give 6 important dimensions. (6)

Ans. Socket and Spigot Cotter Joint (Assembly)

i. Front View (upper Half in Section)

- a. Drawing upper half portion of socket, spigot, clearance on both sides of cotter and 4mm clearance between inner walls of socket and spigot.

- b. Drawing lower half portion of socket, spigot.
 - c. Drawing the cotter.
 - d. Drawing the hatching lines.
- ii. Side View (looking from left):
- a. Drawing five circles along with conventional hatching lines.
 - b. Drawing cotter with hidden lines.
 - c. Drawing cutting plane.

Details:

Printing title (1), scale used (1), drawing projection symbol (1) and six dimensions (3).

OR

Bushed Bearing (Dis-assembly)

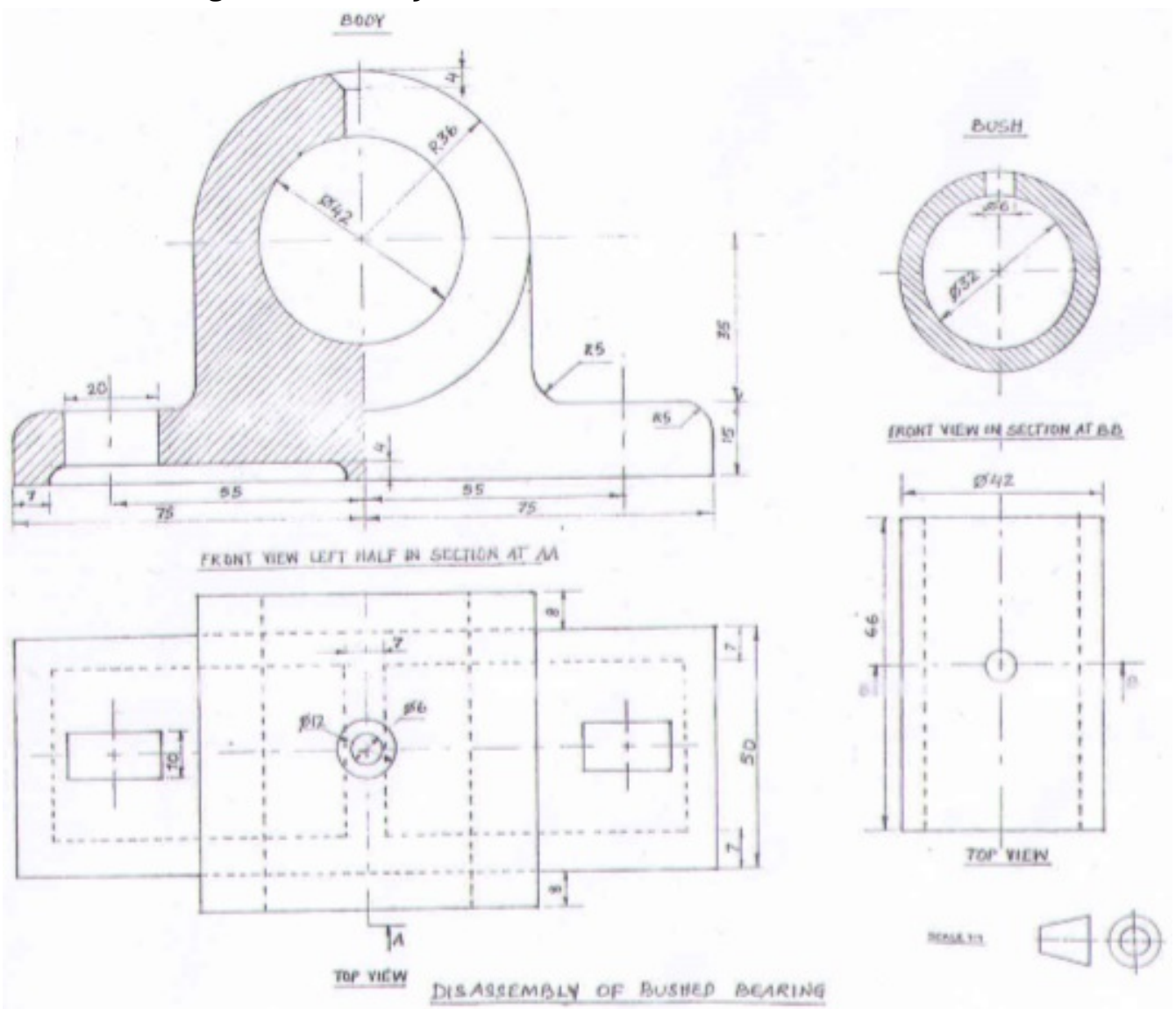

i. Body

a. Front View (left Half in Section):

- (i) Drawing the left half portion of body with recess of 4mm in base plate.
- (ii) Drawing hole of 20×10 (l) and oil here (l).
- (iii) Hatching lines
- (iv) Drawing the right half portion of body with centre line of 2×10 .

b. Top View:

- (i) Drawing the entire boundary with hidden lines.
- (ii) Drawing holes (rectangular or elongated circular and both circles of oil hole.
- (iii) Cutting plane.

ii. Bush

a. Full Sectional Front View:

- (i) Two circles.
- (ii) Oil hole.
- (iii) Hatching lines.

b. Top View:

- (i) Rectangular boundary, hidden line with circle of oil hole.
- (ii) Cutting plane.

Details:

Printing titles of both, scale used, drawing projection symbol and six dimensions.

